

- Three Phase 1/5A Current Transformer operated
- Accuracy Class 1 (Active Energy)
- Bi-directional Measurement for kW and kWh
- Pulse Output
- RS485 Modbus
- Active Energy and Power Measurement
- Resettable energy counter
- Low Cost



The SDM72CT-M is digital three phase 4 wire energy meter with a white back-lighted LCD screen for perfect reading. The unit measures and displays the characteristics of three phase four wires(3p4w) supply, including voltage, frequency, current, power ,active and reactive energy, imported or exported. Energy is measured in terms of kWh, kVAh. The requisite current input(s) are obtained via current transformers(CT). This meter can be configured to work with a wide range of CTs, giving the unit a wide range of operation. Built-in interfaces provides pulse and RS485 Modbus RTU outputs. Configuration is password protected.

Specification table

Specification	
Model	SDM72CT-M
Nominal voltage(Un)	3x230/400 V ac
Operational voltage	80%~120% of Un
Insulation capabilities	
-AC voltage withstand	4KV for 1 minute
-Impulse voltage withstand	6KV~1.2μs
Basic current(Ib)	5A
Maximum rated current(Imax)	6A
Operational current range	0.4% Ib-Imax
Over current withstand	20 Imax for 0.5s
Operational frequency range	50 or 60Hz
Pwer consumption per phase	≤2W/10VA
Pulse output 1	configurable
Pulse output 2	1000imp/kWh
Display	LCD
Max reading	999999.9kWh

Performance criteria	
Operating humidity	≤90%
Storage humidity	≤95%
Operating temperature	-25°C~+55°C
Storage temperature	-40°C~+70°C
Reference temperature	23°C±2°C
International standard	IEC 62053-21

Accuracy class	Class 1
Installation category	CAT III
Mechanical environment	M1
Electromagnetic environment	E2
Degree of pollution	2
Protection against penetration of dust and water	IP51(indoor)
Insulation encased meter of protective class	II
Electrostatic discharges	8kV contact / 15kV air gap
Electromagnetic HF fields	IEC 6100-4-3
Electrical fast transients	4kV
Surge	4kV
Radiated & conducted emissions	EN55022

Modbus	
Bus type	RS485(semi-duplex)
Protocol	Modbus RTU
Baud rate	1200/2400/4800/9600bps
Address range	1-247
Max. Bus loading	64pcs
Communication distance	1000M
Parity	EVEN/ODD/NONE
Data bit	8
Stop bit	1

Wiring Configuration

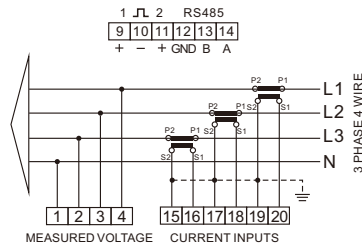

SDM72CT-M

Dimension Drawing

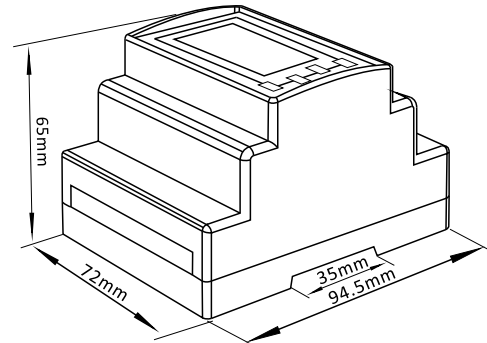

Height 94.5mm
Width 72mm
Depth 65mm

SDM72CT-M

2P3W, 3P4W, 3x230(400)V, Measures active energy & power Bi-directional measurement IMP& EXP Resettable partial energy Pulse output RS485 Modbus RTU, 1A/5A CT operated, Accuracy better than class 1/B.

Ordering options

Meter Type	Description of Meter
SDM72CT-M	2P3W, 3P4W, 3x230(400)V, Measures active/reactive energy, Bi-directional measurement IMP&EXP, Power, Voltage, Current, Frequency, Power factor, Pulse output RS485 Modbus RTU Max. 100A direct connection, Accuracy better than class 1/B

Conformity References

Electromagnetic Compatibility: EN61326-1:2013 & EN61326-2-3:2013

Low Voltage Directive: EN61010-1-2010 & EN61010-2-30-2010